

Built-In Features Eliminate the Need for External Relays when Using the Maxim Driver-Comparator-Load (DCL) and Parametric Measurement Unit (PMU) Chip Sets

The following application note describes the features of Maxim's new PMU and DCL products and utilizes their characteristics for specific PMU output current requirements of less than 2mA or for output current requirements of 2mA to 50mA.

Introduction

In traditional automated semiconductor testing, the DCL and the PMU are alternately connected to the Device Under Test (DUT), using "select relays."

This application note describes the unique built-in features of the Maxim DCLs (MAX9961/62, MAX9967/68) and the PMUs (MAX9949/50, MAX9951/52) that allow the user to eliminate the cost and board space associated with mechanical relays. A secondary benefit is the ability to enhance the conventional current drive capability of low current PMU's by taking advantage of the driver component of the DCL.

Device Description

The MAX9961/62/67/68 are dual, low-power, high-speed pin electronics DCL ICs for Automated Test Equipment (ATE). Each channel includes a 500Mbps Driver, a Window Comparator, Dynamic Clamps, and an Active Load (MAX9961/62 = 2mA max, MAX9967/68 = 35mA max).

The MAX9949/50 are dual PMUs intended for ATE and other instrumentation. The small size, wide force and measurement range and high accuracy make the MAX9949-50 ideal for testers that require a PMU per pin or per site. The MAX9949/50 have a built in external buffer drive feature that can be used to expand the voltage and current range of the PMU depending on the user's application.

Application Example

The built in Force / Sense and low leakage features of the MAX9961/62/67/68 and the external buffer support of the MAX9949/50 allow them to work together to eliminate the need for external select relays.

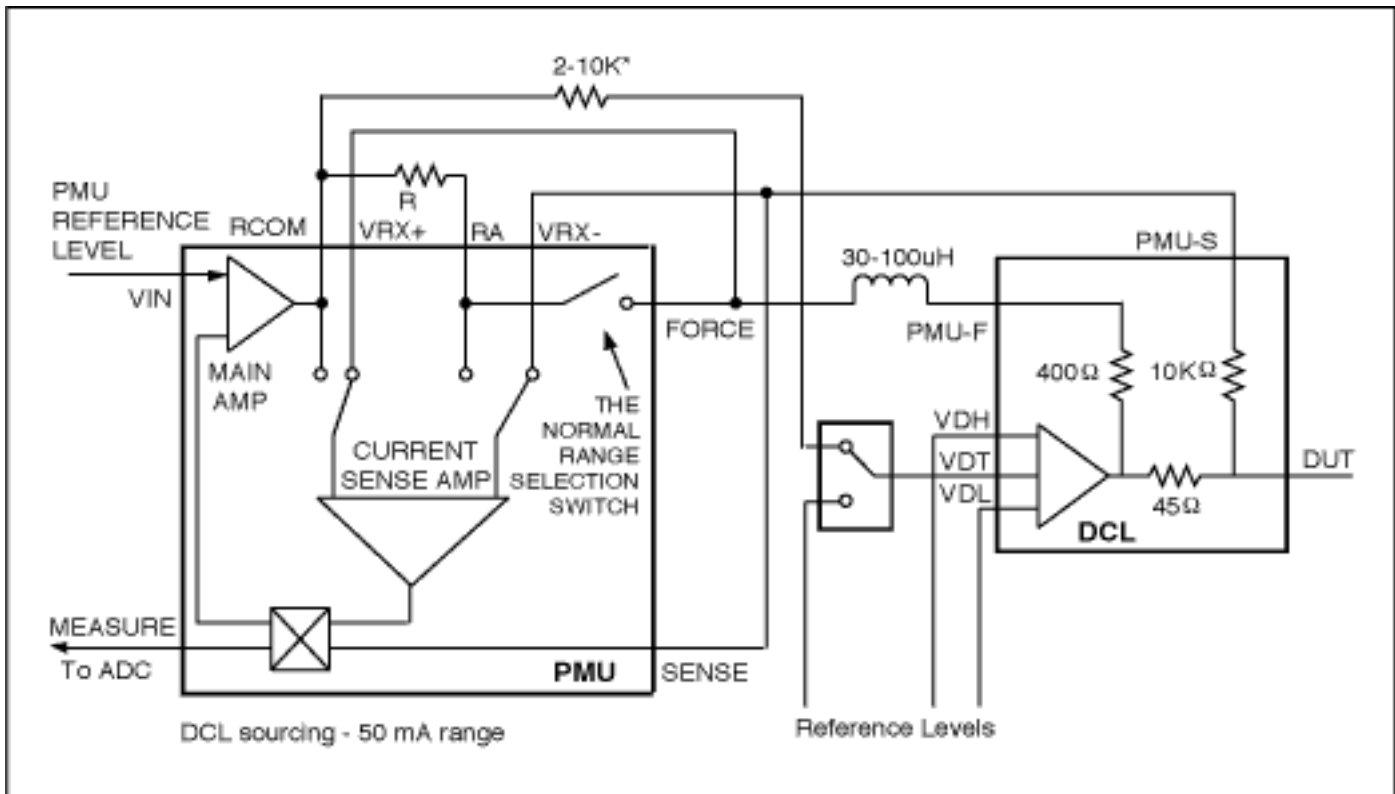

Figure 2

Conclusions

Maxim's DCLs and PMUs plus an analog switch eliminate the need for mechanical relays that add cost and take board space. Using a DCL increases the current drive capability when lower current PMUs are used in a design.

More Information

MAX9949: [QuickView](#) -- [Full \(PDF\) Data Sheet](#)

MAX9950: [QuickView](#) -- [Full \(PDF\) Data Sheet](#)

MAX9961: [QuickView](#) -- [Full \(PDF\) Data Sheet](#) -- [Free Samples](#)

MAX9962: [QuickView](#) -- [Full \(PDF\) Data Sheet](#) -- [Free Samples](#)

MAX9967: [QuickView](#) -- [Full \(PDF\) Data Sheet](#) -- [Free Samples](#)